

**Answers are mark with Bold Red**

1. Consider a water tank shown in the figure. It has one wall at  $x = L$  and can be taken to be very wide in the  $z$  direction. When filled with a liquid of surface tension  $S$  and density  $\rho$ , the liquid surface makes angle  $\theta_0$  ( $\theta_0 \ll 1$ ) with the  $x = L$ . If  $y(x)$  is the height of the surface then the equation for  $y(x)$  is:

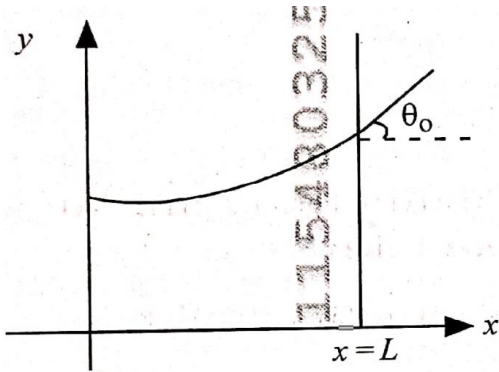

(take  $\theta(x) = \sin \theta(x) = \tan \theta(x) = \frac{dy}{dx}$ ,  $g$  is the acceleration due to gravity)

- (1)  $\frac{d^2y}{dx^2} = \frac{\rho g}{S} x$
  - (2)  $\frac{d^2y}{dx^2} = \frac{\rho g}{S} y$
  - (3)  $\frac{d^2y}{dx^2} = \sqrt{\frac{\rho g}{S}}$
  - (4)  $\frac{dy}{dx} = \sqrt{\frac{\rho g}{S}} x$
2. A microscope has an objective of focal length 2 cm, eyepiece of focal length 4 cm and the tube length of 40 cm. if the distance of distinct vision of eye is 25 cm, the magnification in the microscope is
- (1) 100
  - (2) **125**
  - (3) 150
  - (4) 250

3. An electron (mass  $9 \times 10^{-31}$  kg and charge  $1.6 \times 10^{-19}$ C) moving with speed  $c/100$  ( $c =$  speed of light) is injected into a magnetic field  $\vec{B}$  of magnitude  $9 \times 10^{-4}$  T perpendicular to its direction of motion. We wish to apply an uniform electric field  $\vec{E}$  together with the magnetic field so that the electron does not deflect from its path. Then (speed of light  $c = 3 \times 10^8$   $ms^{-1}$ )
- (1)  $\vec{E}$  is perpendicular to  $\vec{B}$  and its magnitude is  $27 \times 10^4$   $V m^{-1}$
  - (2)  $\vec{E}$  is perpendicular to  $\vec{B}$  and its magnitude is  $27 \times 10^2$   $V m^{-1}$
  - (3)  $\vec{E}$  is parallel to  $\vec{B}$  and its magnitude is  $27 \times 10^2$   $V m^{-1}$
  - (4)  $\vec{E}$  is parallel to  $\vec{B}$  and its magnitude is  $27 \times 10^4$   $V m^{-1}$
4. There are two inclined surfaces of equal length ( $L$ ) and same angle of inclination  $45^\circ$  with the horizontal. One of them is rough and the other is perfectly smooth. A given body takes 2 times as much time to slide down on rough surface than on the smooth surface. The coefficient of kinetic friction ( $\mu_k$ ) between the object and the rough surface is close to
- (1) 0.25
  - (2) 0.40
  - (3) 0.5
  - (4) **0.75**
5. The kinetic energies of two similar cars A and B are 100 J and 225 J respectively. On applying breaks, car A stops after 1000 m and car B stops after 1500 m. If  $F_A$  and  $F_B$  are the forces applied by the breaks on cars A and B, respectively, then the ratio  $F_A/F_B$  is
- (1)  $\frac{3}{2}$
  - (2)  $\frac{2}{3}$
  - (3)  $\frac{1}{3}$
  - (4)  $\frac{1}{2}$

6. The current passing through the battery in the given circuit, is:

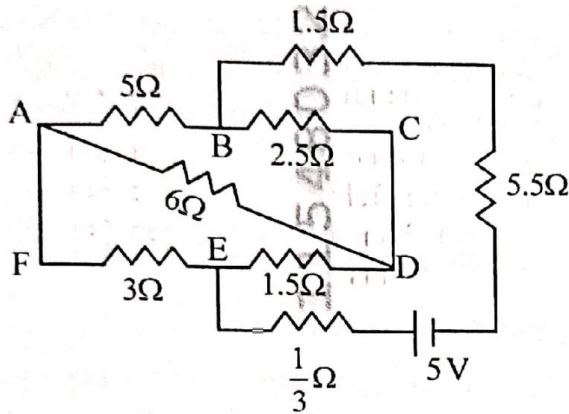

- (1) 2.0 A
- (2) **0.5 A**
- (3) 2.5 A
- (4) 1.5 A

7. A bob of heavy mass  $m$  suspended by a light string of length  $l$ . The bob is given a horizontal velocity  $v_0$  as shown in figure. If the string gets slack at some point  $P$  making an angle  $\theta$  from the horizontal, the ratio of the speed  $v$  of the bob at point  $P$  to its initial speed  $v_0$  is:

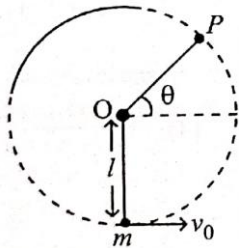

- (1)  $(\sin \theta)^{1/2}$
- (2)  $\left(\frac{1}{2+3 \sin \theta}\right)^{1/2}$
- (3)  $\left(\frac{\cos \theta}{2+3 \sin \theta}\right)^{1/2}$
- (4)  $\left(\frac{\sin \theta}{2+3 \sin \theta}\right)^{1/2}$

8. The output (Y) of the given logic implementation is similar to the output of an/a \_\_\_\_\_ gate.

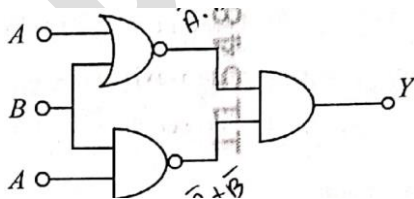

- (1) AND
- (2) NAND
- (3) OR
- (4) **NOR**

9. The electric field in a plane electromagnetic wave is given by

$$E_z = 60 \cos(5x + 1.5 \times 10^9 t) \text{ V/m.}$$

Then expression for the corresponding magnetic field is (here subscripts denote the direction of the field)"

- (1)  **$B_y = 2 \times 10^{-7} \cos(5x + 1.5 \times 10^9 t) T$**
- (2)  $B_x = 2 \times 10^{-7} \cos(5x + 1.5 \times 10^9 t) T$
- (3)  $B_z = 60 \cos(5x + 1.5 \times 10^9 t) T$
- (4)  $B_y = 60 \sin(5x + 1.5 \times 10^9 t) T$

10. A ball of mass 0.5 kg is dropped from a height of 40m. The ball hits the ground and rises to a height of 10m. The impulse imparted to the ball during its collision with the ground is (Take  $g = 9.8 \text{ m/s}^2$ )

- (1) **21 NS**
- (2) 7 NS
- (3) 0
- (4) 84 NS

11. AB is a part of an electrical circuit (see figure). The potential difference " $V_A - V_B$ ", at the instant when current  $i = 2A$  and is increasing at a rate of 1 amp/second is:

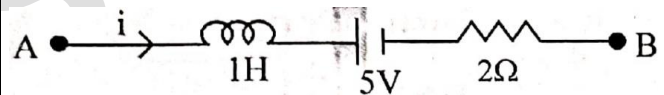

- (1) 5 volt
- (2) 6 volt
- (3) 9 volt
- (4) **10 volt**

12. A 2 amp current is flowing through two different small circular copper coils having radii ratio 1:2. The ratio of their respective magnetic moments will be

- (1) **1:4**
- (2) 1:2
- (3) 2:1
- (4) 4:1

13. In a certain camera, a combination of four similar thin convex lenses are arranged axially in contact. Then the power of the combination and the total magnification in comparison to the power ( $p$ ) and magnification ( $m$ ) for each lens will be, respectively-

- (1)  $4p$  and  $4m$
- (2)  $P^4$  and  $4m$
- (3)  **$4p$  and  $m^4$**
- (4)  $p^4$  and  $m^4$

14. An oxygen cylinder of volume 30 litre has 18.20 moles of oxygen. After some oxygen is withdrawn from the cylinder, its gauge pressure drops to 11 atmospheric pressure at temperature 27°C. The mass of the oxygen withdrawn from the cylinder is nearly equal to:

[Given,  $R = \frac{100}{12} J mol^{-1}K^{-1}$ , and molecular mass of  $O_2 = 32$ , 1 atm pressure =  $1.01 \times 10^5 N/m$ ]

- (1) 0.125 kg
- (2) 0.144 kg
- (3) **0.116 kg**
- (4) 0.156 kg

15. In some appropriate units, time (t) and position (x) relation of a moving particle is given by  $t = x^2 + x$ . The acceleration of the particle is

- (1)  $-\frac{2}{(x+2)^3}$
- (2)  $-\frac{2}{(2x+1)^3}$
- (3)  $+\frac{2}{(x+1)^3}$
- (4)  $+\frac{2}{2x+1}$

16. To an ac power supply of 220 V at 50 Hz, a resistor of  $20\Omega$ , a capacitor of reactance  $25\Omega$ , and an inductor of reactance  $45\Omega$  are connected in series. The corresponding current in the circuit and the phase angle between the current and the voltage is, respectively

- (1) 7.8 A and  $30^\circ$
- (2) **7.8 A and  $45^\circ$**
- (3) 15.6 A and  $30^\circ$
- (4) 15.6 A and  $45^\circ$

17. The Sun rotates around its centre once in 27 days. What will be the period of revolution if the Sun were to expand to twice its present radius without any external influence? Assume the Sun to be a sphere of uniform density

- (1) 100 days
- (2) 105 days
- (3) 115 days
- (4) **108 days**

18. A model for quantized motion of an electron in a uniform magnetic field B states that the flux passing through the orbit of the electron is  $n(h/e)$  where  $n$  is an integer,  $h$  is Planck's constant and  $e$  is the magnitude of electron's charge. According to the model, the magnetic moment of an electron in its lowest energy state will be ( $m$  is the mass of the electron)

- (1)  $\frac{he}{\pi m}$
- (2)  $\frac{he}{2\pi m}$
- (3)  $\frac{heB}{\pi m}$
- (4)  $\frac{heB}{2\pi m}$

19. Three identical heat conducting rods are connected in series as shown in the figure. The rods on the sides have thermal conductivity  $2K$  while that in the middle has thermal conductivity  $K$ . The left end of the combination is maintained at temperature  $3T$  and the right end at  $T$ . The rods are thermally insulated from outside. In steady state, temperature at the left junction is  $T_1$  and that at the right junction is  $T_2$ . The ratio  $T_1/T_2$  is

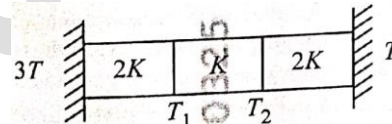

- (1)  $\frac{3}{2}$
- (2)  $\frac{4}{3}$
- (3)  $\frac{5}{3}$
- (4)  $\frac{5}{4}$

20. The plates of a parallel plate capacitor are separated by  $d$ . Two slabs of different dielectric constant  $k_1$  and  $k_2$  with thickness  $\frac{3}{8}d$  and  $\frac{d}{2}$ , respectively are inserted in the capacitor. Due to this, the capacitance becomes two times larger than when there is nothing between the plates.

If  $K_1 = 1.25 K_2$ , the value of  $K_1$  is:

- (1) **2.66**
- (2) 2.33
- (3) 1.60
- (4) 1.33

21. Two cities X and Y are connected by a regular bus service with a bus leaving in either direction every  $T$  min. A girl is driving scooter with a speed of 60 km/h in the direction X to Y notices that a bus goes past her every 30 minutes in the direction of her motion, and every 10 minutes in the opposite direction. Choose the correct option for the period  $T$  of the bus service and the speed (assumed constant) of the buses.

- (1) 9 min, 40 km/h
- (2) 25 min, 100 km/h
- (3) 10 min, 90 km/h
- (4) **15 min, 120 km/h**

22. A uniform rod of mass 20 kg and length 5 m leans against a smooth vertical wall making an angle of  $60^\circ$  with it. The other end rests on a rough horizontal floor. The friction force that the floor exerts on the rod is (take  $g = 10\text{m/s}^2$ )

- (1) 100 N
- (2)  **$100\sqrt{3}$  N**
- (3) 200 N
- (4)  $200\sqrt{3}$  N

23. In an Oscillating spring mass system, a spring is connected to a box filled with sand. As the box oscillates, sand leaks slowly out of the box vertically so that the average frequency  $\omega(t)$  and average amplitude  $A(t)$  of the system change with time  $t$ . Which one of the following options schematically depicts these changes correctly?

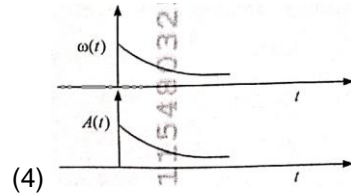
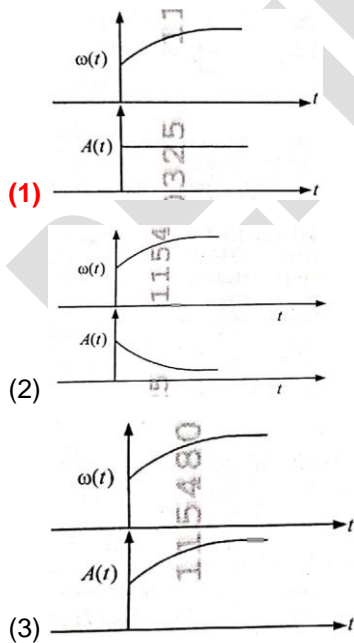

24. A balloon is made of a material of surface tension  $S$  and its inflation outlet (from where gas is filled in it) has small area  $A$ . It is filled with a gas of density  $\rho$  and takes a spherical shape of radius  $R$ . When the gas is allowed to flow freely out of it, its radius  $r$  changes from  $R$  to 0 (zero) in time  $T$ . If the speed  $v(r)$  of gas coming out of the balloon depends on  $r$  as  $r^\alpha$  and  $T \propto S^\alpha A^\beta \rho^\gamma R^\delta$  then

- (1)  $a = \frac{1}{2}, \alpha = \frac{1}{2}, \beta = -1, \gamma = +1, \delta = \frac{3}{2}$
- (2)  $a = -\frac{1}{2}, \alpha = -\frac{1}{2}, \beta = -1, \gamma = -\frac{1}{2}, \delta = \frac{5}{2}$
- (3)  **$a = -\frac{1}{2}, \alpha = -\frac{1}{2}, \beta = -1, \gamma = \frac{1}{2}, \delta = \frac{7}{2}$**
- (4)  $a = \frac{1}{2}, \alpha = \frac{1}{2}, \beta = -\frac{1}{2}, \gamma = \frac{1}{2}, \delta = \frac{7}{2}$

25. Consider the diameter of a spherical object being measured with the help of a Vernier callipers. Suppose its 10 Vernier Scale Divisions (V.S.D.) are equal to its 9 Main Scale Divisions (M.S.D.). The least division in the M.S. is 0.1 cm and the zero of V.S. is at  $x = 0.1$  cm when the jaws of vernier callipers are closed.

If the main scale reading for the diameter is  $M = 5$  cm and the number of coinciding Vernier division is 8, the measured diameter after zero error correction, is

- (1) 5.18 cm
- (2) 5.08 cm
- (3) **4.98 cm**
- (4) 5.00 cm

26. A parallel plate capacitor made of circular plates is being charged such that the surface charge density on its plates increasing at a constant rate with time. The magnetic field arising due to displacement current is:

- (1) Zero at all places
- (2) Constant between the plates and zero outside the plates
- (3) **Non-zero everywhere with maximum at the imaginary cylindrical surface connecting peripheries of the plates**
- (4) Zero between the plates and non-zero outside

27. An unpolarized light beam travelling in air is incident on a medium of refractive index 1.73 at Brewster's angle  
Then-

- (1) **Reflected light is completely polarized and the angle of reflection is close to  $60^\circ$**
- (2) Reflected light is partially polarized and the angle of reflection is close to  $30^\circ$
- (3) Both reflected and transmitted light are perfectly polarized with angles of reflection and refraction close to  $60^\circ$  and  $30^\circ$ , respectively.
- (4) Transmitted light is completely polarized with angle of refraction close to  $30^\circ$

28. Two identical charged conducting spheres A and B have their centres separated by a certain distance charge on each sphere is  $q$  and the force of repulsion between them is  $F$ . A third identical uncharged conducting sphere is brought in contact with sphere A first and then with B and finally removed from both. New force of repulsion between spheres A and B (Radii of A and B are negligible compared to the distance of separation so that for calculating force between them they can be considered as point charges) is best given as:

- (1)  $3F/5$                       (2)  $2F/3$
- (3)  $F/2$                         (4)  **$3F/8$**

29. A container has two chambers of volumes  $V_1 = 2$  litres and  $V_2 = 3$  litres separated by a partition made of a thermal insulator. The chambers contains  $n_1 = 5$  and  $n_2 = 4$  moles of ideal gas at pressures  $p_1 = 1$  atm and  $p_2 = 2$  atm. Respectively. When the partition is removed, the mixture attains an equilibrium pressure of :

- (1) 1.3 atm                      (2) **1.6 atm**
- (3) 1.4 atm                      (4) 1.8 atm

30. A particle of mass  $m$  is moving around the origin with a constant force  $F$  pulling it towards the origin. If Bohr model is used to describe its motion, the radius  $r$  of the  $n^{\text{th}}$  orbit and the particle's speed  $v$  in the orbit depend on  $n$  as

- (1)  $r \propto n^{1/3}; v \propto n^{1/3}$       (2)  $r \propto n^{1/3}; v \propto n^{2/3}$
- (3)  **$r \propto n^{2/3}; v \propto n^{1/3}$**     (4)  $r \propto n^{4/3}; v \propto n^{-1/3}$

31. The radius of Martian orbit around the Sun is about 4 times the radius of the orbit of Mercury. The Martian year is 687 Earth days. Then which of the following is the length of 1 year of Mercury?

- (1) **88 earth days**            (2) 225 earth days
- (3) 72 earth days              (4) 24 earth days

32. A body weighs 48 N on the surface of the earth. The gravitational force experienced by the body due to the earth at a height equal to one-third the radius of the earth from its surface is :

- (1) 16 N                         (2) **27 N**
- (3) 32 N                         (4) 36 N

33. A wire of resistance  $R$  is cut into 8 equal pieces. From these pieces two equivalent resistance are made by adding four of these together in parallel. Then these sets are added in series. The net effective resistance of the combination is :

- (1)  $R/64$                         (2)  $R/32$
- (3)  **$R/16$**                         (4)  $R/8$

34. De-Broglie wavelength of an electron orbiting in the  $n = 2$  state of hydrogen atom is close to (Given Bohr radius =  $0.052 \text{ nm}$ )

- (1)  $0.067 \text{ nm}$                 (2)  **$0.67 \text{ nm}$**
- (3)  $1.67 \text{ nm}$                  (4)  $2.67 \text{ nm}$

35. An electro dipole with dipole moment  $5 \times 10^{-6} \text{ cm}$  is aligned with the direction of a uniform electric field of magnitude  $4 \times 10^5 \text{ N/C}$ . the dipole is then rotated through an angle of  $60^\circ$  with respect to the electric field. The change in the potential energy of the dipole is :

- (1) 0.8 J                         (2) **1.0 J**
- (3) 1.2 J                         (4) 1.5 J

36. A constant voltage of 50 V is maintained between the points A and B of the circuit shown in the figure. The current through the branch CD of the circuit is :

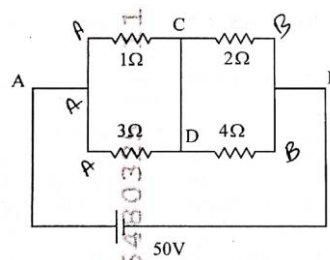

- (1) 1.5 A                         (2) **2.0 A**
- (3) 2.5 A                         (4) 3.0 A

37. The photon and an electron (mass  $m$ ) have the same energy  $E$ . The ratio ( $\lambda_{\text{photon}} / \lambda_{\text{electron}}$ ) of their de Broglie wavelengths is : ( $c$  is the speed of light)

- (1)  $\sqrt{\frac{E}{2m}}$
- (2)  $c\sqrt{2mE}$
- (3)  $c\sqrt{\frac{2E}{E}}$
- (4)  $\frac{1}{c}\sqrt{\frac{E}{2m}}$

38. Which of the following options represent the variation of photoelectric current with property of light shown on the x-axis?

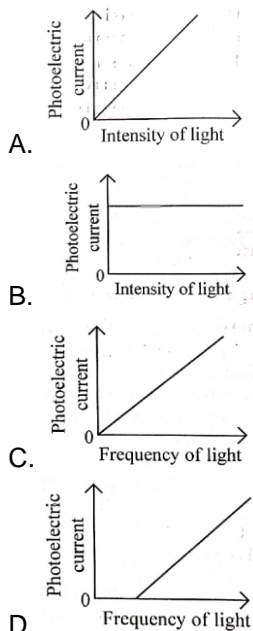

- (1) **A only**
- (2) A and C
- (3) A and D
- (4) B and D

39. A sphere of radius  $R$  is cut from a larger solid sphere of radius  $2R$  as shown in the figure. The ratio of the moment of inertia of the smaller sphere to that of the rest part of the sphere about the Y-axis is :

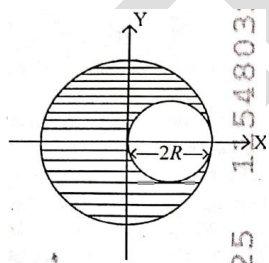

- (1) 7/8
- (2) 7/40
- (3) **7/57**
- (4) 7/64

40. A full wave rectifier circuit with diodes ( $D_1$ ) and ( $D_2$ ) is shown in the figure. If input supply voltage  $V_{in} = 220 \sin(100\pi t)$  volt, then at  $t = 15 \text{ msec}$

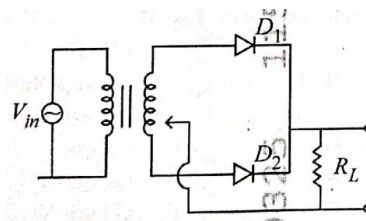

- (1)  $D_1$  is forward biased,  $D_2$  is reverse biased
- (2)  **$D_1$  is reverse biased,  $D_2$  is forward biased**
- (3)  $D_1$  and  $D_2$  both are forward biased
- (4)  $D_1$  and  $D_2$  both are reverse biased

41. Two gases A and B are filled at the same pressure in separate cylinders with movable pistons of radius  $r_A$  and  $r_B$  respectively. On supplying an equal amount of heat to both the systems reversible under constant pressure, the pistons of gas A and B are displaced by 16 cm and 9 cm, respectively. If the change in their internal energy is same, then the ratio  $r_A/r_B$  is equal to

- (1)  $\frac{4}{3}$
- (2)  **$\frac{3}{4}$**
- (3)  $\frac{2}{\sqrt{3}}$
- (4)  $\frac{\sqrt{3}}{2}$

42. A physical quantity  $P$  is related to four observation  $a, b, c$  and  $d$  as follows :

$$P = a^3 b^2 / c \sqrt{d}$$

The percentage errors of measurement in  $a, b, c$  and  $d$  are 1%, 3%, 2% and 4% respectively. The percentage error in the quantity  $P$  is

- (1) 10%
- (2) 2%
- (3) **13%**
- (4) 15%

43. The intensity of transmitted light when a polaroid sheet, placed between two crossed polaroids at  $22.5^\circ$  from the polarization axis of one of the polaroids is ( $I_0$  is the intensity of polarized light after passing through the first polaroid) :

- (1)  $I_0/2$
- (2)  $I_0/4$
- (3)  **$I_0/8$**
- (4)  $I_0/16$

44. Two identical point masses P and Q, suspended from two separate massless springs of spring constant  $k_1$  and  $k_2$  respectively, oscillate vertically. If their maximum speeds are the same, the ratio ( $A_Q/A_P$ ) of the amplitude  $A_Q$  of mass Q to the amplitude  $A_P$  of mass P is :

- (1)  $\frac{k_2}{k_1}$  (2)  $\frac{k_1}{k_2}$   
 (3)  $\sqrt{\frac{k_2}{k_1}}$  (4)  $\sqrt{\frac{k_1}{k_2}}$

45. A pipe open at both ends has a fundamental frequency  $f$  in air. The pipe is now dipped vertically in a water drum of half of its length. The fundamental frequency of the air column is now equal to :

- (1)  $f/2$  (2)  $f$   
 (3)  $3f/2$  (4)  $2f$

46. The ratio of the wavelengths of the light absorbed by a Hydrogen atom when it undergoes  $n = 2 \rightarrow n = 3$  and  $n = 4 \rightarrow n = 6$  transitions, respectively, is:

- (1)  $\frac{1}{36}$   
 (2)  $\frac{1}{16}$   
 (3)  $\frac{1}{9}$   
 (4)  $\frac{1}{4}$

47. Which of the following statements are true?

- A. Unlike Ga that has a very high melting point, Cs has a very low melting point.  
 B. On Pauling scale, the electronegativity values of N and Cl are not the same  
 C. Ar,  $K^+$ ,  $Cl^-$ ,  $Ca^{2+}$ , and  $S^{2-}$  are all isoelectronic species.  
 D. The correct order of the first ionization enthalpies of Na, Mg, Al, and Si is  $Si > Al > Mg > Na$ .  
 E. The atomic radius of Cs is greater than that of Li and Rb.

Choose the **correct** answer from the options given below:

- (1) A, B and E only  
 (2) **C and E only**  
 (3) C and D only  
 (4) A, C, and E only

48. Match List I with List II.

	List I (Iron)		List II (Group Number in Cation Analysis)
A.	$Co^{2+}$	I.	Group I
B.	$Mg^{2+}$	II.	Group III
C.	$Pb^{2+}$	III.	Group IV
D.	$Al^{3+}$	IV.	Group VI

Choose the **correct** answer from the options given below:

- (1) A-III, B-IV, C-II, D-I  
 (2) **A-III, B-IV, C-I, D-II**  
 (3) A-III, B-II, C-IV, D-I  
 (4) A-III, B-II, C-I, D-IV

49. Predict the major product 'P' in the following sequence of reactions –

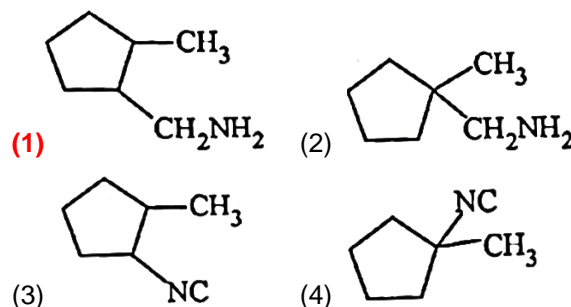
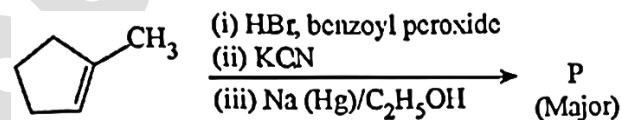

50. Energy and radius of first Bohr orbit of  $He^+$  and  $Li^{2+}$  are:

[Given  $R_H = 2.18 \times 10^{-18} J$ ,  $a_0 = 52.9 pm$ ]

- (1)  $E_n(Li^{2+}) = -19.62 \times 10^{-18} J$ ;  
 $r_n(Li^{2+}) = 17.6 pm$   
 $E_n(He^+) = -8.72 \times 10^{-18} J$ ;  
 $r_n(He^+) = 26.4 pm$   
 (2)  $E_n(Li^{2+}) = -8.72 \times 10^{-18} J$ ;  
 $r_n(Li^{2+}) = 26.4 pm$   
 $E_n(He^+) = -19.62 \times 10^{-18} J$ ;  
 $r_n(He^+) = 17.6 pm$   
 (3)  $E_n(Li^{2+}) = -19.62 \times 10^{-16} J$ ;  
 $r_n(Li^{2+}) = 17.6 pm$   
 $E_n(He^+) = -8.72 \times 10^{-16} J$ ;

$$r_n(He^+) = 26.4 \text{ pm}$$

$$(4) E_n(Li^{2+}) = -8.72 \times 10^{-16} \text{ J};$$

$$r_n(Li^{2+}) = 17.6 \text{ pm}$$

$$E_n(He^+) = -19.62 \times 10^{-16} \text{ J};$$

$$r_n(He^+) = 17.6 \text{ pm}$$

51. Which of the following are paramagnetic?

- A.  $[NiCl_4]^{2-}$   
 B.  $Ni(CO)_4$   
 C.  $[Ni(CN)_4]^{2-}$   
 D.  $[Ni(H_2O)_6]^{2+}$   
 E.  $Ni(PPH_3)_4$

Choose the **correct** answer from the options given below:

- (1) A and C only            (2) B and E only  
**(3) A and D only**            (4) A, D and E only

52. Given below are two statements:

**Statement I:** Like nitrogen that can form ammonia, arsenic can form arsine.

**Statement II:** Antimony cannot form antimony pentoxide.

In the light of the above statements, choose the **most appropriate** answer from the options given below:

- (1) Both Statement I and Statement II are correct  
 (2) Both Statement I and Statement II are incorrect  
**(3) Statement I is correct but Statement II is incorrect**  
 (4) Statement I is incorrect but Statement II is correct

53. Which among the following electronic configurations belong to main group elements?

- A.  $[Ne]3s^1$   
 B.  $[Ar]3d^34s^2$   
 C.  $[Kr]4d^{10}5s^25p^5$   
 D.  $[Ar]3d^{10}4s^1$   
 E.  $[Rn]5f^06d^27s^2$

Choose the **correct** answer from the option given below:

- (1) B and E only            **(2) A and C only**  
 (3) D and E only            (4) A, C and D only

54. Dalton's Atomic theory could not explain which of the following?

- (1) Law of conservation of mass  
 (2) Law of constant proportion  
 (3) Law of multiple proportion  
**(4) Law of gaseous volume**

55. Consider the following compounds:

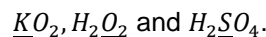

The oxidation states of the underlined elements in them are respectively,

- (1) **+1, -1 and +6**            (2) +2, -2 and +6  
 (3) +1, -2, and +4            (4) +4, -4, and +6

56. If the half-life ( $t_{1/2}$ ) for a first order reaction is 1 minute, then the time required for 99.9% completion of the reaction is closest to:

- (1) 2 minutes            (2) 4 minutes  
 (3) 5 minutes            **(4) 10 minutes**

57. The correct order of the wavelength of light absorbed by the following complexes is,

- A.  $[Co(NH_3)_6]^{3+}$             B.  $[Co(CN)_6]^{3-}$   
 C.  $[Cu(H_2O)_4]^{2+}$             D.  $[Ti(H_2O)_6]^{3+}$

Choose the **correct** answer from the options given below:

- (1) B < D < A < C            **(2) B < A < D < C**  
 (3) C < D < A < B            (4) C < A < D < B

58. Which one of the following compounds can exist as cis-trans isomers?

- (1) Pent-1-ene  
 (2) 2-Methylhex-2-ene  
 (3) 1, 1-Dimethylcyclopropane  
**(4) 1, 2-Dimethylcyclohexane**

59. Phosphoric acid ionizes in three steps with their ionization constant values  $K_{a_1}$ ,  $K_{a_2}$  and  $K_{a_3}$  respectively, while K is the overall ionization constant.

Which of the following statements are true?

- A.  $\log K = \log K_{a_1} + \log K_{a_2} + \log K_{a_3}$   
 B.  $H_3PO_4$  is a stronger acid than  $H_2PO_4^-$  and  $HPO_4^{2-}$   
 C.  $K_{a_1} > K_{a_2} > K_{a_3}$   
 D.  $K_{a_1} = \frac{K_{a_3} + K_{a_2}}{2}$

Choose the **correct** answer from the options given below:

- (1) A and B only            (2) A and C only  
 (3) B, C and D only            **(4) A, B and C only**



60. Which one of the following reactions does **NOT** give benzene as the product?

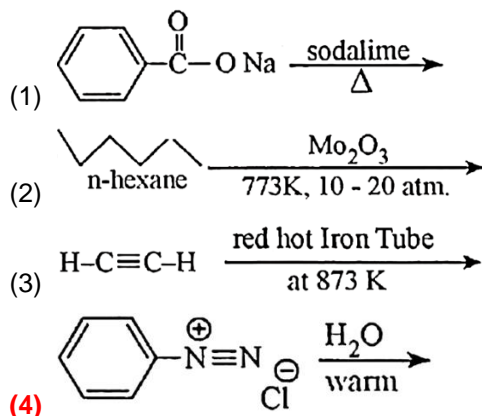

61. If the molar conductivity ( $\Lambda_m$ ) of a  $0.050 \text{ mol L}^{-1}$  solution of a monobasic weak acid is  $90 \text{ S cm}^2 \text{ mol}^{-1}$ , its extent (degree) of dissociation will be:

[Assume  $\Lambda_+^\circ = 349.6 \text{ S cm}^2 \text{ mol}^{-1}$  and  $\Lambda_-^\circ = 50.4 \text{ S cm}^2 \text{ mol}^{-1}$ ].

- (1) 0.115                      (2) 0.125  
 (3) **0.225**                      (4) 0.215

62. Given below are two statements:

**Statement I:** A hypothetical diatomic molecule with bond order zero is quite stable.

**Statement II:** As bond order increases, the bond length increases.

In the light of the above statements, choose the **most appropriate** answer from the options given below:

- (1) Both Statement I and Statement II are true  
 (2) **Both Statement I and Statement II are false**  
 (3) Statement I is true but Statement II is false  
 (4) Statement I is False but Statement II is True

63. Out of the following complex compounds, which of the compound will be having the minimum conductance in solution?

- (1)  $[\text{Co}(\text{NH}_3)_3\text{Cl}_3]$               (2)  $[\text{Co}(\text{NH}_3)_4\text{Cl}_2]$   
 (3)  $[\text{Co}(\text{NH}_3)_6]\text{Cl}_3$               (4)  $[\text{Co}(\text{NH}_3)_5\text{Cl}]\text{Cl}$

64. Match List I with List II.

	List I		List II
A.	XeO <sub>3</sub>	I.	sp <sup>3</sup> d; linear
B.	XeF <sub>2</sub>	II.	sp <sup>3</sup> ; pyramidal

C.	XeOF <sub>4</sub>	III.	sp <sup>3</sup> d <sup>3</sup> ; distorted octahedral
D.	XeF <sub>6</sub>	IV.	sp <sup>3</sup> d <sup>2</sup> ; square pyramidal

Choose the **correct** answer from the options given below:

- (1) **A-II, B-I, C-IV, D-III**  
 (2) A-II, B-I, C-III, D-IV  
 (3) A-IV, B-II, C-III, D-I  
 (4) A-IV, B-II, C-I, D-III

65.  $\text{C}(s) + 2\text{H}_2(g) \rightarrow \text{CH}_4(g); \Delta H = -74.8 \text{ kJ mol}^{-1}$ .

Which of the following diagrams gives an accurate representation of the above reactions?

[R → reactants; P → products]

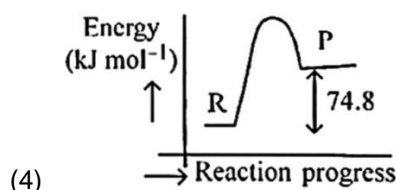
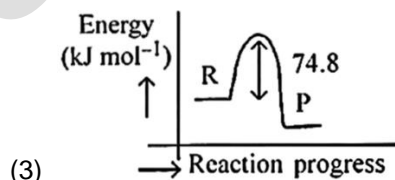
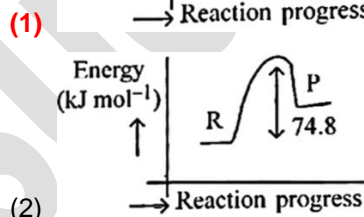
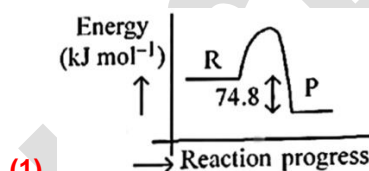

66. Match List I with List II.

	List I (Example)		List II (Type of Solution)
A.	Humidity	I.	Solid in solid
B.	Alloys	II.	Liquid in gas
C.	Amalgams	III.	Solid in gas
D.	Smoke	IV.	Liquid in solid

Choose the **correct** answer from the options given below:

(1) A-II, B-IV, C-I, D-III

 (2) **A-II, B-I, C-IV, D-III**

(3) A-III, B-I, C-IV, D-II

(4) A-III, B-II, C-I, D-IV

67. The correct order of decreasing basic strength of the given amines is:

(1) N-methylaniline &gt; benzenamine &gt; ethanamine &gt; N-ethylethanamine

(2) N-ethylethanamine &gt; ethanamine &gt; benzenamine &gt; N-methylaniline

 (3) **N-ethylethanamine > ethanamine > N-methylaniline > benzenamine**

(4) benzenamine &gt; ethanamine &gt; N-methylaniline &gt; N-ethylethanamine

68. Among the following, choose the ones with equal number of atoms.

 A. 212 g of  $\text{Na}_2\text{CO}_3(\text{s})$  [molar mass = 106 g]

 B. 248 g of  $\text{Na}_2\text{O}(\text{s})$  [molar mass = 62 g]

 C. 240 g of  $\text{NaOH}(\text{s})$  [molar mass = 40 g]

 D. 12 g of  $\text{H}_2(\text{g})$  [molar mass = 2 g]

 E. 220 g of  $\text{CO}_2(\text{g})$  [molar mass = 44 g]

Choose the **correct** answer from the options given below:

 (1) A, B, and C only      (2) **A, B and D only**

(3) B, C and D only      (4) B, D and E only

69. Match List I with List II.

	List I (Name of Vitamin)		List II (Deficiency disease)
A.	Vitamin B <sub>12</sub>	I.	Cheilosis
B.	Vitamin D	II.	Convulsions
C.	Vitamin B <sub>2</sub>	III.	Rickets
D.	Vitamin B <sub>6</sub>	IV.	Pernicious anaemia

Choose the **correct** answer from the options given below:

(1) A-I, B-III, C-II, D-IV

 (2) **A-IV, B-III, C-I, D-II**

(3) A-II, B-III, C-I, D-IV

(4) A-IV, B-III, C-II, D-I

70. The correct order of decreasing acidity of the following aliphatic acids is:

 (1)  $(\text{CH}_3)_3\text{CCOOH} > (\text{CH}_3)_2\text{CHCOOH} > \text{CH}_3\text{COOH} > \text{HCOOH}$ 

 (2)  $\text{CH}_3\text{COOH} > (\text{CH}_3)_2\text{CHCOOH} > (\text{CH}_3)_3\text{CCOOH} > \text{HCOOH}$ 

 (3)  **$\text{HCOOH} > \text{CH}_3\text{COOH} > (\text{CH}_3)_2\text{CHCOOH} > (\text{CH}_3)_3\text{CCOOH}$** 

 (4)  $\text{HCOOH} > (\text{CH}_3)_3\text{CCOOH} > (\text{CH}_3)_2\text{CHCOOH} > \text{CH}_3\text{COOH}$ 

71. Given below are two statements:

**Statement I:** Ferromagnetism is considered as an extreme form of paramagnetism.

**Statement II:** The number of unpaired electrons in a  $\text{Cr}^{2+}$  ion ( $Z = 24$ ) is the same as that of a  $\text{Nd}^{3+}$  ion ( $Z = 60$ ).

In the light of the above statements, choose the **Correct** answer from the options given below:

(1) Both Statement I and Statement II are true

(2) Both Statement I and Statement II are false

 (3) **Statement I is true but Statement II is false**

(4) Statement I is False but Statement II is True

72. Match List I with List II.

	List I (Mixture)		List II (Method of Separation)
A.	$\text{CHCl}_3 + \text{C}_6\text{H}_5\text{NH}_2$	I.	Distillation under reduced pressure
B.	Crude oil in petroleum industry	II.	Steam distillation
C.	Glycerol from spent-lye	III.	Fractional distillation
D.	Aniline-water	IV.	Simple distillation

Choose the **correct** answer from the options given below:

 (1) **A-IV, B-III, C-I, D-II**

(2) A-IV, B-III, C-II, D-I

(3) A-III, B-IV, C-I, D-II

(4) A-III, B-IV, C-II, D-I

73. For the reaction  $A(g) \rightleftharpoons 2B(g)$ , the backward reaction rate constant is higher than the forward reaction rate constant by a factor of 2500, at 1000 K.

[Given:  $R = 0.0831 \text{ L atm mol}^{-1} \text{ K}^{-1}$ ]

$K_P$  for the reaction at 1000 K is

- (1) 83.1 (2)  $2.077 \times 10^5$   
**(3) 0.033** (4) 0.021

74. Given below are two statements:

**Statement I:** Benzenediazonium salt is prepared by the reaction of aniline with nitrous acid at 273 – 278 K. It decomposes easily in the dry state.

**Statement II:** Insertion of iodine into the benzene ring is difficult and hence iodobenzene is prepared through the reaction of Benzenediazonium salt with KI.

In the light of the above statements, choose the **most appropriate** answer from the options given below:

- (1) **Both Statement I and Statement II are correct**  
 (2) Both Statement I and Statement II are incorrect  
 (3) Statement I is correct but Statement II is incorrect  
 (4) Statement I is incorrect but Statement II is correct

75. How many products (including stereoisomers) are expected from monochlorination of the following compound?

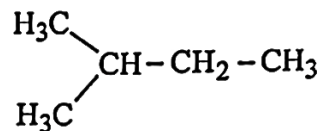

- (1) 2 (2) 3  
 (3) 5 **(4) 6**

76. Among the given compounds I-III, the correct order of bond dissociation energy of C-H bond marked with \* is:

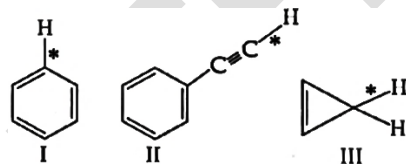

- (1) **II > I > III**  
 (2) I > II > III  
 (3) III > II > I  
 (4) II > III > I

77. Which one of the following compounds **does not** decolorize bromine water?

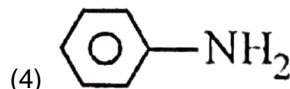
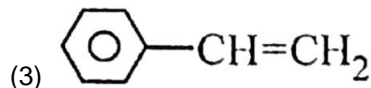
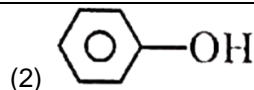
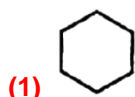

78. The major product of the following reaction is:

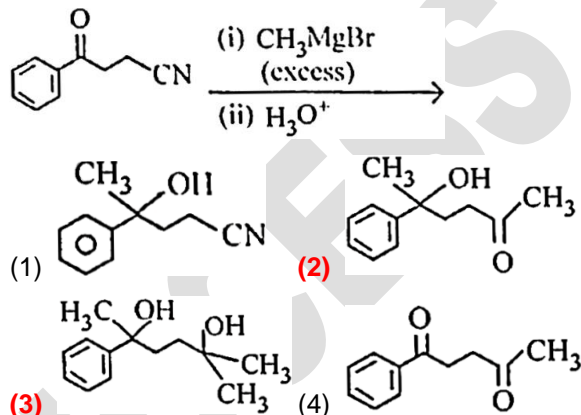

79. Which of the following aqueous solution will exhibit highest boiling point?

- (1) 0.01 M urea (2) 0.01 M  $\text{KNO}_3$   
**(3) 0.01 M  $\text{Na}_2\text{SO}_4$**  (4) 0.015 M  $\text{C}_6\text{H}_{12}\text{O}_6$

80. Match List I with List II.



	List I		List II
A.	Haber process	I.	Fe catalyst
B.	Wacker oxidation	II.	$\text{PdCl}_2$
C.	Wilkinson catalyst	III.	$[(\text{PPh}_3)_3\text{RhCl}]$
D.	Ziegler catalyst	IV.	$\text{TiCl}_4$ with $\text{Al}(\text{CH}_3)_3$

Choose the **correct** answer from the options given below:

- (1) A-I, B-II, C-IV, D-III  
 (2) A-II, B-III, C-I, D-IV  
**(3) A-I, B-II, C-III, D-IV**  
 (4) A-I, B-IV, C-III, D-II

81. 5 moles of liquid X and 10 moles of liquid Y make a solution having a vapour pressure of 70 torr. The vapour pressures of pure X and Y are 63 torr and 78 torr respectively. Which of the following is true regarding the described solution?

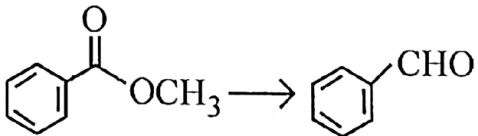
- (1) The solution shows positive deviation

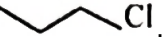
- (2) **The solution shows negative deviation**  
 (3) The solution is ideal  
 (4) The solution has volume greater than the sum of individual volumes.
82. Sugar 'X'
- A. is found in honey.  
 B. is a keto sugar.  
 C. exists in  $\alpha$  and  $\beta$  – anomeric forms.  
 D. Is laevorotatory.
- 'X' is:
- (1) D-Glucose                      **(2) D-Fructose**  
 (3) Maltose                        (4) Sucrose
83. Identify the suitable reagent for the following conversion.
- 
- (1) (i)  $\text{LiAlH}_4$ , (ii)  $\text{H}^+/\text{H}_2\text{O}$   
**(2) (i)  $\text{AlH}(\text{iBu})_2$  (ii)  $\text{H}_2\text{O}$**   
 (3) (i)  $\text{NaBH}_4$ , (ii)  $\text{H}^+/\text{H}_2\text{O}$   
 (4)  $\text{H}_2/\text{Pd}-\text{BaSO}_4$
84. Given below are two statements: One is labeled as **Assertion (A)** and the other is labelled as **Reason (R)**.
- Assertion (A):**  undergoes  $\text{S}_{\text{N}}2$  reaction faster than .
- Reason:** Iodine is a better leaving group because of its larger size.
- In the light of the above statements, choose the **correct** answer from the options given Below:
- (1) **Both A and R are true and R is the correct explanation of A**  
 (2) Both **A** and **R** are true but **R** is not the correct explanation of **A**  
 (3) **A** is true but **R** is false  
 (4) **A** is false but **R** is true
85. The standard heat of formation in kcal/mol of  $\text{Ba}^{2+}$  is:  
 [Given: standard heat of formation of  $\text{SO}_4^{2-}$  ion (aq) = -216 kcal/mol, standard heat of crystallisation of  $\text{BaSO}_4(\text{s})$  = -4.5 kcal/mol, standard heat of formation of  $\text{BaSO}_4(\text{s})$  = -349 kcal/mol]
- (1) **-128.5**                      (2) -133.0  
 (3) +133.0                      (4) +220.5

86. Total number of possible isomers (both structural as well as stereoisomers) of cyclic ethers of molecular formula  $\text{C}_4\text{H}_8\text{O}$  is:
- (1) 6                                      (2) 8  
**(3) 10**                                      (4) 11
87. Identify the correct orders against the property mentioned:
- A.  $\text{H}_2\text{O} > \text{NH}_3 > \text{CHCl}_3$  – dipole moment  
 B.  $\text{XeF}_4 > \text{XeO}_3 > \text{XeF}_2$  – number of lone pairs on central atom  
 C.  $\text{O}-\text{H} > \text{C}-\text{H} > \text{N}-\text{O}$  – Bond length  
 D.  $\text{N}_2 > \text{O}_2 > \text{H}_2$  – bond enthalpy
- Choose the **correct** answer from the options given below:
- (1) **A, D only**  
 (2) B, D only  
 (3) A, C only  
 (4) B, C only
88. Higher yield of NO in  $\text{N}_2(\text{g}) + \text{O}_2(\text{g}) \rightleftharpoons 2\text{NO}(\text{g})$  can be obtained at  $[\Delta H \text{ of the reaction} = +180.7 \text{ kJ mol}^{-1}]$
- A. Higher temperature  
 B. lower temperature  
 C. higher concentration of  $\text{N}_2$   
 D. higher concentration of  $\text{O}_2$
- Choose the **correct** answer from the options given below:
- (1) A, D only  
 (2) B, C only  
 (3) B, C, D only  
 (4) **A, C, D only**
89. If the rate constant of a reaction is  $0.03 \text{ s}^{-1}$ , how much time does it take for  $7.2 \text{ mol L}^{-1}$  concentration of the reactant to get reduced to  $0.9 \text{ mol L}^{-1}$ ?
- (1) **69.3 s**                                      (2) 23.1 s  
 (3) 210 s                                      (4) 21.0 s

90. Which one of the following reactions does **NOT** belong to "Lassaigne's test"?
- (1)  $\text{Na} + \text{C} + \text{N} \xrightarrow{\Delta} \text{NaCN}$
- (2)  $2\text{Na} + \text{S} \xrightarrow{\Delta} \text{Na}_2\text{S}$
- (3)  $\text{Na} + \text{X} \xrightarrow{\Delta} \text{NaX}$
- (4)  $2\text{CuO} + \text{C} \xrightarrow{\Delta} 2\text{Cu} + \text{CO}_2$
91. The complex II of mitochondrial electron transport chain is also known as
- (1) Cytochrome  $\text{bc}_1$
- (2) **Succinate dehydrogenase**
- (3) Cytochrome c oxidase
- (4) NADH dehydrogenase
92. Polymerase chain reaction (PCR) amplifies DNA following the equation.
- (1)  $\text{N}^2$
- (2)  **$2^n$**
- (3)  $2n + 1$
- (4)  $2\text{N}^2$
93. What are the potential drawback in adoption of the IVF method?
- A. High fatality risk to mother
- B. Expensive instruments and reagents
- C. Husband/wife necessary for being donors
- D. Less adoption of orphans
- E. Not available in India
- F. Possibility that the early embryo does not survive
- Choose the correct answer from the options given below:
- (1) **B, D, F only**
- (2) A, C, D only
- (3) A, B, C, D only
- (4) A, B, C, E, F only
94. What is the name of the blood vessel that carries deoxygenated blood from the body to the heart in a frog?
- (1) Aorta
- (2) Pulmonary artery
- (3) Pulmonary vein
- (4) **Vena cava**
95. Which one of the following statements refers to Reductionist Biology?
- (1) **Physico-chemical approach to study and understand living organisms.**
- (2) Physiological approach to study and understand living organisms.
- (3) Chemical approach to study and understand living organisms.
- (4) Behavioural approach to study and understand living organisms.
96. Given below are two statements:
- Statement I :** In the RNA world, RNA is considered the first genetic material evolved to carry out essential life processes. RNA acts as a genetic material and also as a catalyst for some important biochemical reactions in living systems. Being reactive, RNA is unstable.
- Statement II :** DNA evolved from RNA and is a more stable genetic material. Its double helical strands being complementary, resist changes by evolving repairing mechanism.
- In the light of the above statements, choose the **most appropriate** answer from the options given below:
- (1) **Both statement I and statement II are correct**
- (2) Both statement I and statement II are incorrect
- (3) Statement I is correct but statement II is incorrect
- (4) Statement I is incorrect but statement II is incorrect
97. Epiphytes that are growing on a mango branch is an example of which of the following?
- (1) **Commensalism**
- (2) Mutualism
- (3) Predation
- (4) Amensalism
98. From the statements given below choose the **correct** option :
- A. The eukaryotic ribosomes are 80S and prokaryotic ribosomes are 70S.
- B. Each ribosome has two sub-units.
- C. The two sub-units of 80S ribosome are 60S and 40S while that of 70S are 50S and 30S.
- D. The two sub-units of 80S ribosome are 60S and 20S and that of 70S are 50S and 20S.
- E. The two sub-units of 80S are 60S and 30S and that of 70S are 50S and 30S.
- (1) **A, B, C are true**
- (2) A, B, D are true
- (3) A, B, E are true

(4) B, D, E are true

99. Which one of the following is an example of ex-situ conservation?

- (1) National Park
- (2) Wildlife Sanctuary
- (3) **Zoos and botanical gardens**
- (4) Protected areas

100. Given below are two statements :

**Statement I :** The primary source of energy in an ecosystem is solar energy.

**Statement II :** The rate of production of organic matter during photosynthesis in an ecosystem is called net primary productivity (NPP).

In the light of above statements, choose the **most appropriate** answer from the options given below :

- (1) Both statement I and statement II are correct
- (2) Both statement I and statement II are incorrect
- (3) **Statement I is correct but statement II is incorrect**
- (4) Statement I is incorrect but statement II is correct

101. Match List – I with List – II.

	List - I		List – II
A.	Emphysema	I.	Rapid spasms in muscle due to low Ca <sup>++</sup> in body fluid
B.	Angina Pectoris	II.	Damaged alveolar walls and decreased respiratory surface
C.	Glomerulonephritis	III.	Acute chest pain when not enough oxygen is reaching to heart muscle
D.	Tetany	IV	Inflammation of glomeruli of kidney

Choose the **correct** answer from the options given below:

- (1) A-III, B-I, C-IV, D-II
- (2) A-III, B-I, C-II, D-IV
- (3) A-II, B-IV, C-III, D-I
- (4) **A-II, B-III, C-IV, D-I**

102. Given below are two statements : One is labelled as

**Assertion (A)** and the other is labelled as **Reason (R)**.

**Assertion (A) :** Both wind and water pollinated flowers are not very colourful and do not produce nectar.

**Reason (R) :** The flowers produce enormous amount of pollen grains in wind and water pollinated flowers.

In the light of the above statements, choose the **correct** answer from the options given below :

- (1) Both **A** and **R** are true and **R** is the correct explanation of **A**
- (2) **Both A and R are true and R is NOT the correct explanation of A**
- (3) **A** is true but **R** is false
- (4) **A** is false but **R** is true

103. Which of the following is an example of non-distilled alcoholic beverage produced by yeast?

- (1) Whisky
- (2) Brandy
- (3) **Beer**
- (4) Rum

104. Given below are two statements :

**Statement I :** In a floral formula ⊕ stands for zygomorphic nature of the flower, and ⊙ stands for inferior ovary.

**Statement II :** In a floral formula ⊕ stands for actinomorphic nature of the flower and ⊙ stands for superior ovary.

In the light of the above statements, choose the **correct** answer from the options given below :

- (1) Both Statement I and Statement II are correct
- (2) Both Statement I and Statement II are incorrect
- (3) Statement I is correct but Statement II is incorrect
- (4) **Statement I is incorrect but Statement II is correct**

105. Streptokinase produced by *bacterium Streptococcus* is used for

- (1) Curd production
- (2) Ethanol production
- (3) Liver disease treatment
- (4) **Removing clots from blood vessels**

- 106.** Which chromosome in the human genome has the highest number of genes?
- (1) Chromosome X
  - (2) Chromosome Y
  - (3) **Chromosome 1**
  - (4) Chromosome 10
- 107.** Which of the following statement is **correct** about location of the male frog copulatory pad?
- (1) First and Second digit of fore limb
  - (2) First digit of hind limb
  - (3) Second digit of fore limb
  - (4) **First digit of the fore limb**
- 108.** Which one of the following phytohormones promotes nutrient mobilization which helps in the delay of leaf senescence in plants?
- (1) Ethylene
  - (2) Abscisic acid
  - (3) Gibberellin
  - (4) **Cytokinin**
- 109.** While trying to find out the characteristic of a newly found animal, a researcher did the histology of adult animal and observed a cavity with presence of mesodermal tissue towards the body wall but no mesodermal tissue was observed towards the alimentary canal. What could be the possible coelom of that animal?
- (1) Acoelomate
  - (2) **Pseudocoelomate**
  - (3) Schizocoelomate
  - (4) Spongocoelomate

**110.** Match List – I with List – II

	List - I		List – II
A.	Head	I.	Enzymes
B.	Middle piece	II.	Sperm motility
C.	Acrosome	III.	Energy
D.	Tail	IV.	Genetic material

Choose **correct** answer from the options given below:

- (1) **A-IV, B-III, C-I, D-II**
- (2) A-IV, B-III, C-II, D-I
- (3) A-III, B-IV, C-II, D-I
- (4) A-III, B-II, C-I, D-IV

**111.** Given below are the stages in the life cycle of pteridophytes. Arrange the following stages in the correct sequence.

- A. Prothallus stage
- B. Meiosis in spore mother cells
- C. Fertilisation
- D. Formation of archegonia and antheridia in gametophyte.
- E. Transfer of antherozoids to the archegonia in presence of water.

Choose the **correct** answer from the options given below:

- (1) **B, A, D, E, C**
- (2) B, A, E, C, D
- (3) D, E, C, A, B
- (4) E, D, C, B, A

**112.** Cardiac activities of the heart are regulated by :

- A. Nodal tissue
- B. A special neural centre in the medulla oblongata
- C. Adrenal medullary hormones
- D. Adrenal cortical hormones

Choose the **correct** answer from the options given below:

- (1) A, B and C only
- (2) **A, B, C and D**
- (3) A, C and D only
- (4) A, B and D only

**113.** Which of following organisms *cannot* fix nitrogen?

- A. *Azotobacter*
- B. *Oscillatoria*
- C. *Anabaena*
- D. *Volvox*
- E. *Nostoc*

Choose the **correct** answer from the options given below:

- (1) A only
- (2) **D only**
- (3) B only
- (4) E only

114. Given below are two statements :

**Statement I :** Transfer RNAs and ribosomal RNA do not interact with mRNA.

**Statement II :** RNA interference (RNAi) takes place in all eukaryotic organisms as a method of cellular defense. In the light of the above statements, choose the **most appropriate** answer from the options given below :

- (1) Both Statement I and Statement II are correct
- (2) Both Statement I and Statement II are incorrect
- (3) Statement I is correct but Statement II is incorrect
- (4) **Statement I is incorrect but Statement II is correct**

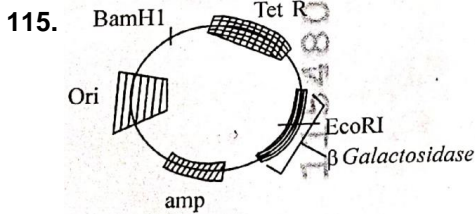

In the above represented plasmid an alien piece of DNA is inserted at EcoRI site. Which of the following strategies will be chosen to select the recombinant colonies?

- (1) Using ampicillin & tetracycline containing medium plate.
- (2) Blue color colonies will be selected.
- (3) **White color colonies will be selected.**
- (4) Blue color colonies grown on ampicillin plates can be selected.

116. Which of the following genetically engineered organisms was used by Eli Lilly to prepare human insulin?

- (1) **Bacterium**
- (2) Yeast
- (3) Virus
- (4) Phage

117. Name the class of enzyme that usually catalyze the following reaction :



Where, G → a group other than hydrogen

S → a substrate

S<sup>#</sup> → another substrate

- (1) Hydrolase
- (2) Lyase
- (3) **Transferase**
- (4) Ligase

118. Find the statement that is **NOT** correct with regard to the structure of monocot stem.

- (1) **Hypodermis is parenchymatous.**
- (2) Vascular bundles are scattered.
- (3) Vascular bundles are conjoint and closed.
- (4) Phloem parenchyma is absent.

119. The correct sequence of events in the life cycle of bryophytes is

- A. Fusion of antherozoid with egg.
- B. Attachment of gametophyte to substratum.
- C. Reduction division to produce haploid spores.
- D. Formation of sporophyte.
- E. Release of antherozoids into water.

Choose the **correct** answer from the options given below:

- (1) D, E, A, C, B
- (2) B, E, A, C, D
- (3) **B, E, A, D, C**
- (4) D, E, A, B, C

120. Which are correct:

- A. Computed tomography and magnetic resonance imaging detect cancers of internal organs.
- B. Chemotherapeutics drugs are used to kill non-cancerous cells.
- C. α-interferon activate the cancer patients' immune system and helps in destroying the tumor.
- E. Chemotherapeutic drugs are biological response modifiers.
- E. In the case of leukemia blood cell counts are decreased.

Choose the **correct** answer from the options given below:

- (1) B and D only
- (2) D and E only
- (3) C and D only
- (4) **A and C only**



121. Match List – I with List – II.

	List - I		List – II
A.	Centromere	I.	Mitochondrion
B.	Cilium	II.	Cell division
C.	Cristae	III.	Cell movement
D.	Cell membrane	IV.	Phospholipid Bilayer

Choose **correct** answer from the options given below:

- (1) A-I, B-II, C-III, D-IV
- (2) A-II, B-I, C-IV, D-III
- (3) A-IV, B-II, C-III, D-I
- (4) **A-II, B-III, C-I, D-IV**

122. Match List – I with List – II.

	List - I		List – II
A.	Chlorophyll a	I.	Yellow-green
B.	Chlorophyll b	II.	Yellow
C.	Xanthophylls	III.	Blue-green
D.	Carotenoids	IV.	Yellow to Yellow-orange

Choose **correct** answer from the options given below:

- (1) A-III, B-IV, C-II, D-I
- (2) **A-III, B-I, C-II, D-IV**
- (3) A-I, B-II, C-IV, D-III
- (4) A-I, B-IV, C-III, D-II

123. Find the correct statements :

- A. In human pregnancy, the major organ systems are formed at the end of 12 weeks.
- B. In human pregnancy the major organ systems are formed at the end of 8 weeks.
- C. In human pregnancy heart is formed after one month of gestation.
- D. In human pregnancy, limbs and digits develop by the end of second month.
- E. In human pregnancy the appearance of hair is usually observed in the fifth month.

Choose **correct** answer from the options given below:

- (1) A and E Only
- (2) B and C Only
- (3) B, C, D and E Only
- (4) **A, C, D and E Only**

124. In the seeds of cereals, the outer covering of endosperm

separates the embryo by a protein-rich layer called :

- (1) Coleoptile
- (2) Coleorhiza
- (3) Integument
- (4) **Aleurone layer**

125. Which of the following diagrams is correct with regard to the proximal (P) and distal (D) tubule of the Nephron.

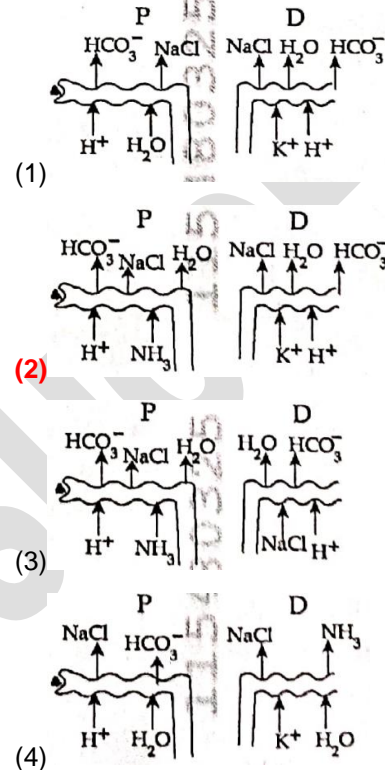

126. Identify the part of a bio-reactor which is used as a foam breaker from the given figure.

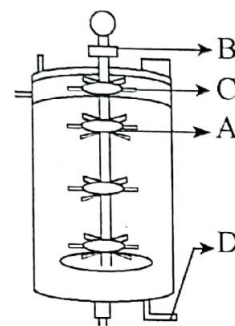

- (1) A
- (2) B
- (3) D
- (4) **C**

127. Given below are two statements : One is labelled as

**Assertion (A)** and the other is labelled as **Reason (R)**.

**Assertion (A)** : A typical unfertilized, angiosperm embryo sac at maturity is 8 nucleate and 7-celled.

**Reason (R)** : The egg apparatus has 2 polar nuclei.

In the light of the above statements, choose the **correct** answer from the options given below :

- (1) Both **A** and **R** are true and **R** is the correct explanation of **A**
- (2) Both **A** and **R** are true but **R** is **NOT** the correct explanation of **A**
- (3) **A is true but R is false**
- (4) **A** is false but **R** is true

128. A specialised membranous structure in a prokaryotic cell which helps in cell wall formation, DNA replication and respiration is

- (1) **Mesosome**
- (2) Chromatophores
- (3) Cristae
- (4) Endoplasmic Reticulum

129. Which of the following are the post-transcriptional events in an eukaryotic cell?

- A. Transport of pre-mRNA to cytoplasm prior to splicing.
- B. Removal of introns and joining of exons.
- C. Addition of methyl group at 5' end of hnRNA.
- D. Addition of adenine residues at 3' end of hnRNA.
- E. Base pairing of two complementary RNAs.

Choose **correct** answer from the options given below:

- (1) A, B, C only
- (2) **B, C, D only**
- (3) B, C, E only
- (4) C, D, E only

130. What is the pattern of inheritance for polygenic trait?

- (1) Mendelian inheritance pattern
- (2) **Non-mendelian inheritance pattern**
- (3) Autosomal dominant pattern
- (4) X-linked recessive inheritance pattern

131. Which one of the following enzymes contains 'Haem' as the prosthetic group?

- (1) RuBisCo
- (2) Carbonic anhydrase
- (3) Succinate dehydrogenase
- (4) **Catalase**

132. Each of the following characteristics represent a

Kingdom proposed by Whittaker. Arrange the following in increasing order of complexity of body organization.

- A. Multicellular heterotrophs with cell wall made of chitin.
- B. Heterotrophs with tissue/organ/organ system level of body organization.
- C. Prokaryotes with cell wall made of polysaccharides and amino acids.
- D. Eukaryotic autotrophs with tissue/organ level of body organization.
- E. Eukaryotes with cellular body organization.

Choose **correct** answer from the options given below:

- (1) A, C, E, B, D
- (2) **C, E, A, D, B**
- (3) A, C, E, D, B
- (4) C, E, A, B, D

133. Who is known as the father of Ecology in India?

- (1) S. R. Kashyap
- (2) **Ramdeo Misra**
- (3) Ram Udar
- (4) Birbal Sahni

134. Match **List – I** with **List – II**.

	<b>List - I</b>		<b>List – II</b>
A.	Alfred Hershey and Martha Chase	I.	Streptococcus pneumoniae
B.	Euchromatin	II.	Densely packed and dark-stained
C.	Frederick Griffith	III.	Loosely packed and light-stained
D.	Heterochromatin	IV.	DNA as genetic material confirmation

Choose the **correct** answer from the options given below:

- (1) A-II, B-IV, C-I, D-III
- (2) A-IV, B-II, C-I, D-III
- (3) **A-IV, B-III, C-I, D-II**
- (4) A-III, B-II, C-IV, D-I

135. Neoplastic characteristics of cells refers to :

- A. A mass of proliferating cell
- B. Rapid growth of cells
- C. Invasion and damage to the surrounding tissue
- D. Those confined to original location

Choose the **correct** answer from the options given below:

- (1) A, B only
- (2) **A, B, C only**
- (3) A, B, D only
- (4) B, C, D only

136. Given below are two statements:

**Statement I:** The DNA fragments extracted from gel electrophoresis can be used in construction of recombinant DNA.

**Statement II:** Smaller size DNA fragments are observed near anode while larger fragments are found near the well in an agarose gel.

In the light of the above statements, choose the **most appropriate** answer from the options given below:

- (1) **Both statement I and statement II are correct**
- (2) Both statement I and statement II are incorrect
- (3) Statement I is correct but statement II is incorrect
- (4) Statement I is incorrect but statement II is correct

137. Match List I with List II.

**List I**

**List II**

- |                  |                  |
|------------------|------------------|
| A. Adenosine     | I. Nitrogen base |
| B. Adenylic acid | II. Nucleotide   |
| C. Adenine       | III. Nucleoside  |
| D. Alanine       | IV. Amino acid   |

Choose the option with all **correct** matches.

- (1) A-III, B-IV, C-II, D-I
- (2) A-III, B-II, C-IV, D-I
- (3) **A-III, B-II, C-I, D-IV**
- (4) A-II, B-III, C-I, D-IV

138. Consider the following:

- A. The reductive division for the human female gametogenesis starts earlier than that of the male gametogenesis.

- B. The gap between the first meiotic division and the second meiotic division is much shorter for males compared to females.
- C. The first polar body is associated with the formation of the primary oocyte.
- D. Luteinizing Hormone (LH) surge leads to disintegration of the endometrium and onset of menstrual bleeding.

Choose the **correct** answer from the options given below:

- (1) **A and B are true**
- (2) A and C are true
- (3) B and D are true
- (4) B and C are true

139. All living members of the class Cyclostomata are:

- (1) Free living
- (2) Endoparasite
- (3) Symbiotic
- (4) **Ectoparasite**

140. Given below are two statements : one is labelled as

**Assertion (A)** and the other is labelled as **Reason (R)**.

( )

**Assertion (A) :** The primary function of the Golgi apparatus is to package the materials made by the endoplasmic reticulum and deliver it to intracellular targets and outside the cell.

**Reason (R) :** Vesicles containing materials made by the endoplasmic reticulum fuse with the cis face of the Golgi apparatus, and they are modified and released from the trans face of the Golgi apparatus.

In the light of the above statements, choose the **correct** answer from the options given below:

- (1) **Both A and R are true and R is the correct explanation of A**
- (2) Both **A** and **R** are true but **R** is **not** the correct explanation of **A**
- (3) **A** is true but **R** is false
- (4) **A** is false but **R** is true

141. Match List I with List II :

**List I**

**List II**

- |                        |                               |
|------------------------|-------------------------------|
| A. Scutellum           | I. Persistent nucellus        |
| B. Non-albuminous seed | II. Cotyledon of Monocot seed |
| C. Epiblast            | III. Groundnut                |
| D. Perisperm           | IV. Rudimentary cotyledon     |

Choose the option with all **correct** matches.

- (1) **A-II, B-III, C-IV, D-I**
- (2) A-IV, B-III, C-II, D-I
- (3) A-IV, B-III, C-I, D-II
- (4) A-II, B-IV, C-III, D-I

142. Given below are two statements : one is labelled as **Assertion (A)** and the other is labelled as **Reason (R)**.

**Assertion (A)** : All vertebrates are chordates but all chordates are not vertebrate.

**Reason (R)** : The members of subphylum vertebrata possess notochord during the embryonic period, the notochord is replaced by a cartilaginous or bony vertebral column in adults.

In the light of the above statements, choose the **correct** answer from the options given below:

- (1) **Both A and R are true and R is the correct explanation of A**
- (2) Both **A** and **R** are true but **R** is **not** the correct explanation of **A**
- (3) **A** is true but **R** is false
- (4) **A** is false but **R** is true

143. Identify the statement that is **NOT** correct.

- (1) Each antibody has two light and two heavy chains.
- (2) The heavy and light chains are held together by disulfide bonds.
- (3) **Antigen binding site is located at C-terminal region of antibody molecules.**
- (4) Constant region of heavy and light chains are located at C-terminus of antibody molecules.

144. Silencing of specific mRNA is possible via RNAi because of –

- (1) **Complementary dsRNA**
- (2) Inhibitory ssRNA
- (3) Complementary tRNA
- (4) Non-complementary ssRNA

145. Genes R and Y follow independent assortment.

If RRYYY produce round yellow seeds and rryy produce wrinkled green seeds, what will be the phenotypic ratio of F<sub>2</sub> generation?

- (1) Phenotypic ratio – 1 : 2 : 1
- (2) Phenotypic ratio – 3 : 1
- (3) **Phenotypic ratio – 9 : 3 : 3 : 1**
- (4) Phenotypic ratio – 9: 7

146. Histones are enriched with –

- (1) **Lysine & Arginine**
- (2) Leucine & Lysine
- (3) Phenylalanine & Leucine
- (4) Phenylalanine & Arginine

147. The first menstruation is called :

- (1) Menopause
- (2) **Menarche**
- (3) Diapause
- (4) Ovulation

148. Match List – I with List – II.

List – I	List – II
A. Heart	I. Erythropoietin
B. Kidney	II. Aldosterone
C. Gastro-intestinal tract	III. Atrial natriuretic factor
D. Adrenal cortex	IV. Secretin

Choose the **correct** answer from the options given below :

- (1) A-II, B-I, C-III, D-IV
- (2) A-IV, B-III, C-II, D-I
- (3) A-I, B-III, C-IV, D-II
- (4) **A-III, B-I, C-IV, D-II**

149. The protein portion of an enzyme is called :

- (1) Cofactor
- (2) Coenzyme
- (3) **Apoenzyme**
- (4) Prosthetic group

150. Which of the following is the unit of productivity of an Ecosystem?

- (1) gm<sup>-2</sup>
- (2) KCal m<sup>-2</sup>
- (3) KCal m<sup>-3</sup>
- (4) **(KCal m<sup>-2</sup>)yr<sup>-1</sup>**

151. Sweet potato and potato represent a certain type of evolution. Select the correct combination of terms to explain the evolution.

- (1) **Analogy, convergent**
- (2) Homology, divergent
- (3) Homology, convergent
- (4) Analogy, divergent

152. With the help of given pedigree, find out the probability for the birth of a child having no disease and being a carrier (has the disease mutation in one allele of the gene) in F<sub>3</sub> generation.

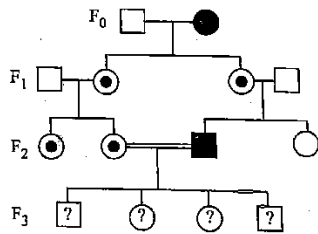

- (1) **1/4**
- (2) 1/2
- (3) 1/8
- (4) Zero

153. Given below are two statements : One is labelled as **Assertion (A)** and the other is labelled as **Reason (R)**.

**Assertion (A)** : Cells of the tapetum possess dense cytoplasm and generally have more than one nucleus.  
**Reason (R)** : Presence of more than one nucleus in the tapetum increases the efficiency of nourishing the developing microspore mother cells.

In the light of the above statements, choose the **most appropriate** answer from the options given below:

- (1) **Both A and R are true and R is the correct explanation of A**
- (2) Both **A** and **R** are true but **R** is **NOT** the correct explanation of **A**
- (3) **A** is true but **R** is false
- (4) **A** is false but **R** is true

154. How many meiotic and mitotic divisions need to occur for the development of mature female gametophyte from the megaspore mother cell in an angiosperm plant?

- (1) 2 Meiosis and 3 Mitosis
- (2) 1 Meiosis and 2 Mitosis
- (3) **1 Meiosis and 3 Mitosis**
- (4) No Meiosis and 2 Mitosis

155. Which of the following is an example of a zygomorphic flower?

- (1) Petunia
- (2) Datura
- (3) **Pea**
- (4) Chilli

156. After maturation, in primary lymphoid organs, the lymphocytes migrate for interaction with antigens to secondary lymphoid organ(s) / tissue(s) like:

- A. thymus
- B. bone marrow
- C. spleen
- D. lymph nodes
- E. Peyer's patches

Choose the *correct* answer from the options given below:

- (1) B, C, D only
- (2) A, B, C only
- (3) E, A, B only
- (4) **C, D, E only**

157. Given below are two statements:

**Statement I**: Fig fruit is a non-vegetarian fruit as it has enclosed fig wasps in it.

**Statement II**: Fig wasp and fig tree exhibit mutual relationship as fig wasp completes its life cycle in fig fruit and fig fruit gets pollinated by fig wasp:

In the light of the above statements, choose the **most appropriate** answer from the options given below :

- (1) **Both statement I and statement II are correct**
- (2) Both statement I and statement II are incorrect
- (3) Statement I is correct but statement II is incorrect
- (4) Statement I is incorrect but statement II is correct

158. What is the main function of the spindle fibers during mitosis?

- (1) **To separate the chromosomes**
- (2) To synthesize new DNA
- (3) To repair damaged DNA
- (4) To regulate cells growth

159. Which one of the following is the characteristic feature of gymnosperms?

- (1) Seeds are enclosed in fruits.
- (2) **Seeds are naked.**
- (3) Seeds are absent.
- (4) Gymnosperms have flowers for reproduction.

160. Consider the following statements regarding function of adrenal medullary hormones.

- A. It causes pupillary constriction
- B. It is a hyperglycemic hormone

C. It causes piloerection  
 D. It increases strength of heart contraction  
 Choose the **correct** answer from the options given below :

- (1) C and D Only      **(2) B, C and D Only**  
 (3) A, C and D Only      (4) D Only

**161.** Why can't insulin be given orally to diabetic patients?

- (1) Human body will elicit strong immune response  
**(2) It will be digested in Gastro-Intestinal (GI) tract**  
 (3) Because of structural variation  
 (4) Its bioavailability will be increased

**162.** Match List I with List II.

List I	List II
A. Pteridophyte	I. <i>Salvia</i>
B. Bryophyte	II. <i>Ginkgo</i>
C. Angiosperm	III. <i>Polytrichum</i>
D. Gymnosperm	IV. <i>Salvinia</i>

Choose the option with all **correct** matches.

- (1) A-III, B-IV, C-II, D-I  
**(2) A-IV, B-III, C-I, D-I**  
 (3) A-III, B-IV, C-I, D-II  
 (4) A-IV, B-III, C-II, D-I

**163.** Who proposed that the genetic code for amino acids should be made up of three nucleotides?

- (1) **George Gamow**      (2) Francis Crick  
 (3) Jacque Monod      (4) Franklin Stahl

**164.** Match List I with List II :

List I	List II
A. The Evil Quartet	I. Cryopreservation
B. Ex situ conservation	II. Alien species invasion
C. <i>Lantana camara</i>	III. Causes of biodiversity losses
D. Dodo	IV. Extinction

Choose the option with all correct matches.

- (1) A-III, B-II, C-I, D-IV  
**(2) A-III, B-I, C-II, D-IV**  
 (3) A-III, B-IV, C-II, D-I  
 (4) A-III, B-II, C-IV, D-I

**165.** Which of the following hormones released from the pituitary is actually synthesized in the hypothalamus?

- (1) Luteinizing hormone (LH)  
**(2) Anti-diuretic hormone (ADH)**  
 (3) Follicle-stimulating hormone (FSH)  
 (4) Adenocorticotrophic hormone (ACTH)

**166.** Role of the water vascular system in Echinoderms is

- A. Respiration and Locomotion  
 B. Excretion and Locomotion  
 C. Capture and transport of food  
 D. Digestion and Respiration  
 E. Digestion and Excretion

Choose the **correct** answer from the options given below

- (1) A and B Only      **(2) A and C Only**  
 (3) B and C Only      (4) B, D and E Only

**167.** Which of the following type of immunity is present at the time of birth and is a non-specific type of defence in the human body?

- (1) Acquired Immunity  
**(2) Innate Immunity**  
 (3) Cell-mediated immunity  
 (4) Humoral Immunity

**168.** In bryophytes, the gemmae help in which one of the following?

- (1) Sexual reproduction  
**(2) Asexual reproduction**  
 (3) Nutrient absorption  
 (4) Gaseous exchange

**169.** In frog, the Renal portal system is a special venous connection that acts to link :

- (1) Liver and intestine  
 (2) Liver and kidney  
 (3) Kidney and intestine  
**(4) Kidney and lower part of body**

170. Given below are two statements :

**Statement I :** In ecosystem, there is unidirectional flow of energy of sun from producers to consumers.

**Statement II :** Ecosystems are exempted from 2<sup>nd</sup> law of thermodynamics.

In the light of the above statements, choose the **most appropriate** answer from the options given below :

- (1) Both statement I and II are correct
- (2) Both statement I and statement II are incorrect
- (3) **Statement I is correct but statement II is incorrect**
- (4) Statement I is incorrect by statement II is correct

171. Which of the following statements about RuBisCO is true?

- (1) It is active only in the dark.
- (2) It has higher affinity for oxygen than carbon dioxide.
- (3) It is an enzyme involved in the photolysis of water.
- (4) **It catalyzes the carboxylation of RuBP.**

172. Which of the following enzyme(s) are **NOT** essential for gene cloning?

- A. Restriction enzymes
- B. DNA ligase
- C. DNA mutase
- D. DNA recombinase
- E. DNA polymerase

Choose the **correct** answer from the options given below:

- (1) **C and D only**
- (2) A and B only
- (3) D and E only
- (4) B and C only

173. Read the following statements on plant growth and development.

- A. Parthenocarpy can be induced by auxins.
- B. Plant growth regulators can be involved in promotion as well as inhibition of growth.
- C. Dedifferentiation is pre-requisite for re-differentiation.
- D. Abscisic acid is a plant growth promoter.
- E. Apical dominance promotes the growth of lateral buds.

Choose the option with all correct statements.

- (1) **A, B, C only**
- (2) A, C, E only
- (3) A, D, E only
- (4) B, D, E only

174. Which factor is important for termination of transcription?

- (1)  $\alpha$  (alpha)
- (2)  $\sigma$  (sigma)
- (3)  **$\rho$  (rho)**
- (3)  $\gamma$  (gamma)

175. Frogs respire in water by skin and buccal cavity and on land by skin, buccal cavity and lungs.

Choose the **correct** answer from the following :

- (1) The statement is true for water but false for land
- (2) The statement is true for both the environment
- (3) **The statement is false for water but true for land**
- (4) The statement is false for both the environment

176. Twins are born to a family that lives next door to you.

The twins are a boy and a girl. Which of the following must be true?

- (1) They are monozygotic twins.
- (2) **They are fraternal twins.**
- (3) They were conceived through in vitro fertilization.
- (4) They have 75% identical genetic content.

177. Which of the following microbes is **NOT** involved in the preparation of household products?

- A. *Aspergillus niger*
- B. *Lactobacillus*
- C. *Trichoderma polysporum*
- D. *Saccharomyces cerevisiae*
- E. *Propionibacterium sharmanii*

Choose the **correct** answer from the options given below:

- (1) A and B only
- (2) **A and C only**
- (3) C and D only
- (4) C and E only

178. Match List-I with List-II.

- | List-I                            | List-II              |
|-----------------------------------|----------------------|
| A. Progesterone                   | I. Pars intermedia   |
| B. Relaxin                        | II. Ovary            |
| C. Melanocyte stimulating hormone | III. Adrenal Medulla |
| D. Catecholamines                 | IV. Corpus luteum    |

Choose the **correct** answer from the options given below:

- (1) **A-IV, B-II, C-I, D-III**
- (2) A-IV, B-II, C-III, D-I
- (3) A-II, B-IV, C-I, D-III
- (4) A-III, B-II, C-IV, D-I

179. The blue and white selectable markers have been developed which differentiate recombinant colonies from non-recombinant colonies on the basis of their ability to produce colour in the presence of a chromogenic substrate.

Given below are two statements about this method:

**Statement I :** The blue coloured colonies have DNA insert in the plasmid and they are identified as recombinant colonies.

**Statement II :** The colonies without blue colour have DNA insert in the plasmid and are identified as recombinant colonies.

In the light of the above statements, choose the **most appropriate** answer from the options given below :

- (1) Both Statement I and Statement II are correct
- (2) Both Statement I and Statement II are incorrect
- (3) Statement I is correct but Statement II is incorrect
- (4) **Statement I is incorrect but Statement II is correct**

180. Which one of the following equations represents the Verhulst-Pearl Logistic Growth of population?

(1) 
$$\frac{dN}{dt} = r \left( \frac{K - N}{K} \right)$$

(2) 
$$\frac{dN}{dt} = rN \left( \frac{K - N}{K} \right)$$

(3) 
$$\frac{dN}{dt} = rN \left( \frac{N - K}{N} \right)$$

(4) 
$$\frac{dN}{dt} = N \left( \frac{r - K}{K} \right)$$